

MARK	QTY	DESCRIPTION	LENGHT	WEIGHT	GRADE	REMARKS
	ONE	MISC		136		
Qbp169	1	BPL25x143	1351	38	300W	BENT
Qbp167	1	BPL25x143	1351	38	300W	BENT
Qbp170	1	BPL13x229	1288	30	300W	BENT
Qbp171	1	BPL13x229	1288	30	300W	BENT
pa	1	BPL13			300W	BENT
pb	1	BPL13			300W	BENT
ma	8	NUT 27 Dia			F53	

MARK	QTY	DESCRIPTION	LENGTH	WEIGHT	GRADE	REMARKS
		FIELD BOLTS				
8		25 Dia A325N	76			1HD WASH

DRAW BY	DF	VERIFY BY	EC
PAINT	2-75	STD HOLES	21 \emptyset U/N
MAIN STEEL	300W	WELD	E49XX
DRAWING REFERENCE			
ED4-8			
AXIS YY-XX, CAP FOR HUB C4020			

PROJECT	C09963	DIV.	4	M4015-B \triangle
 Quirionmetal STRUCTURE D'ACIER / STRUCTURAL STEEL				
CONTRACT NAME				
CATHEDRAL OF THE HOLY FAMILY				
SASKATOON, SASKATCHEWAN				
#	DESCRIPTION	DATE	BY	
.	.	.	.	

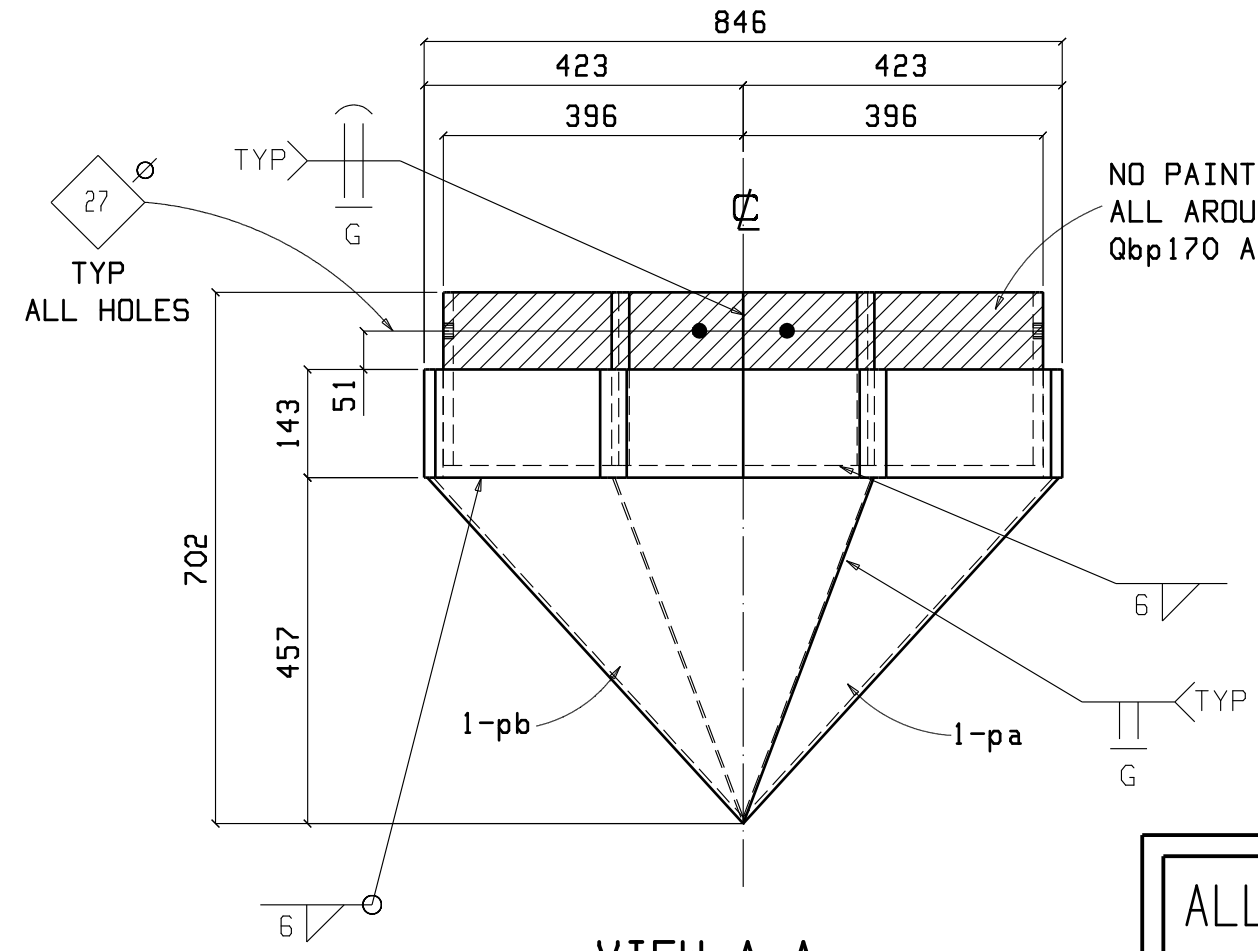
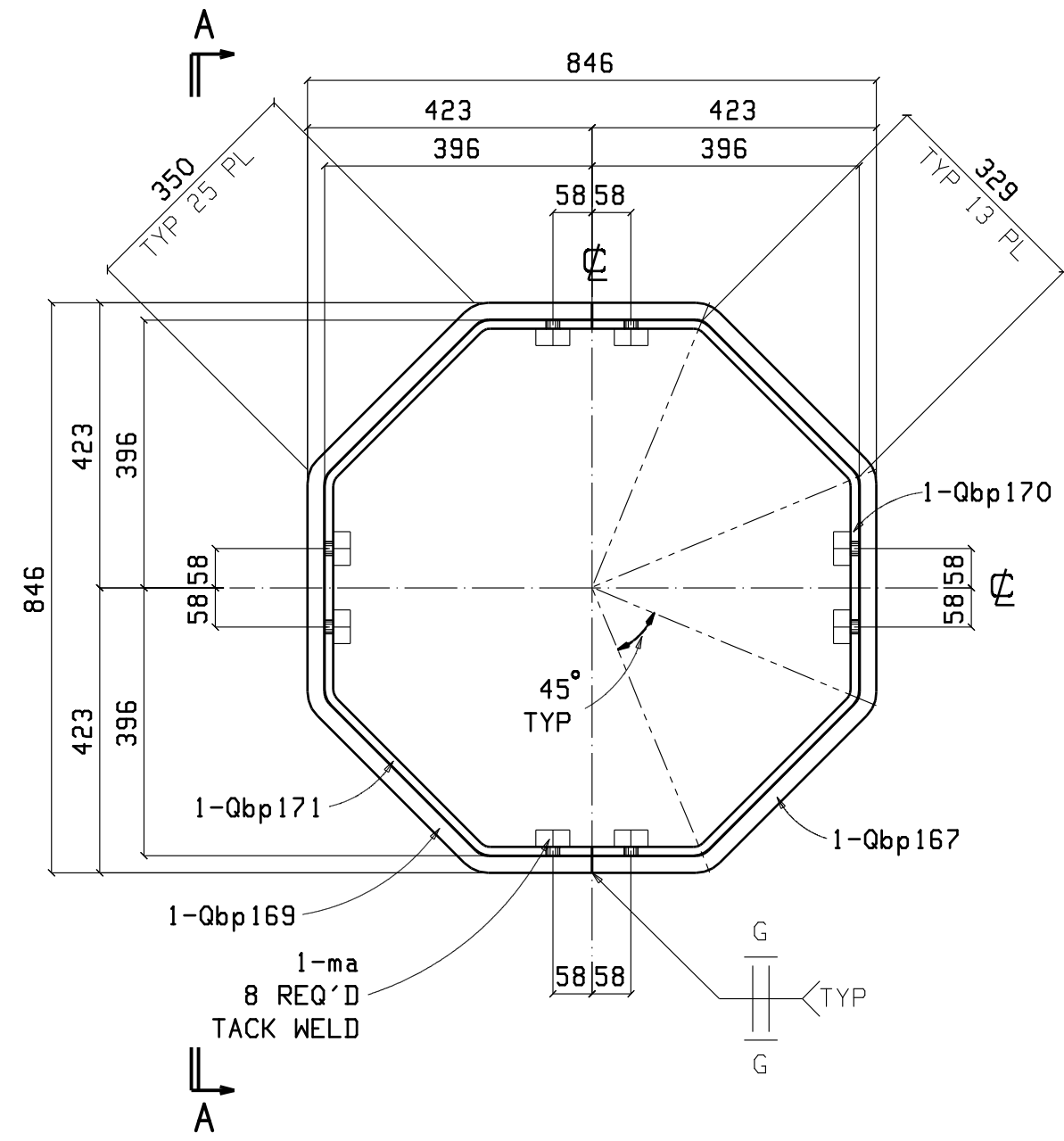

ONE MISC M4015

FOR pa AND pb IF POSSIBLE MAKE 2 BENT PLATE 4 SIDES EACH, IF NOT POSSIBLE, CUT 8 PLATES TRIANGULAR SHAPE.

ALL WELDS TO BE GROUND SMOOTH

SEAL WELD

